

Tech Lift M4

Self Supporting Open Platform Lift



The Swedish designed Tech Lift M4 open platform lift is an elegant easily installed way to provide access at the front or rear of a home up to 1.5 meters - it can even be used inside for a split level.

Based on 4 telescopic lifting columns means there is no need for a bulky mast on one side and efficient use of available space for a very reliable lift.

Available in both residential and commercial models.



RATED LOAD
350kg



TRAVEL HEIGHT
Up to 1.5m



LOCATION
Indoor or Outdoor



CAPACITY
2 people



LANDINGS
2



DRIVE SYSTEM
Telescopic posts



DOOR
Manual or Auto



INSTALL TIME
1 day



POWER SUPPLY
240V, Single phase,
50Hz 10aMp



WARRANTY
3 years



CONFIGURATION
Through car



MANUFACTURED IN
Sweden



COMPLIANT WITH
Australian Standard
AS1735.15



PLATFORM SIZE
1100mm wide x1400mm deep
908mm wide x 1435mm deep

EXTERNAL SIZE
1355mm wide x 1541mm deep
1151mm wide x 1536mm deep

LIFT DRAWINGS

LARGE - 1100mm wide x 1400mm deep platform - 1355mm wide x 1541mm deep footprint

Minimum width for installation 1451 mm

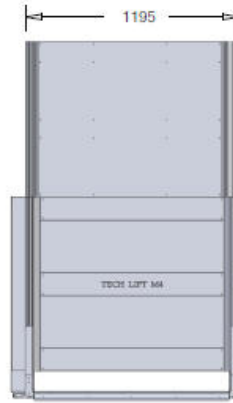
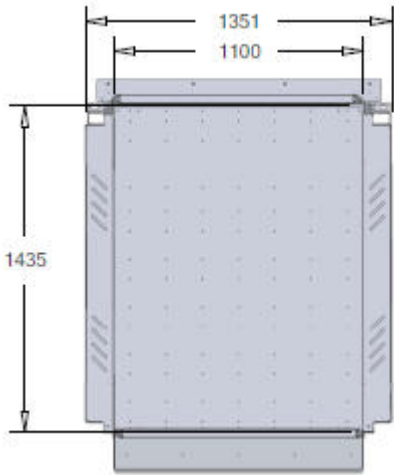

Minimum height from floor to platform 37,5 mm

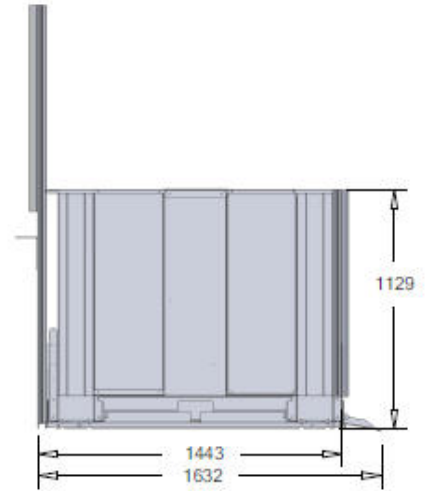

SMALL - 908mm wide x 1435mm deep platform - 1151mm wide x 1536mm deep footprint

Minimum width for installation 1252 mm

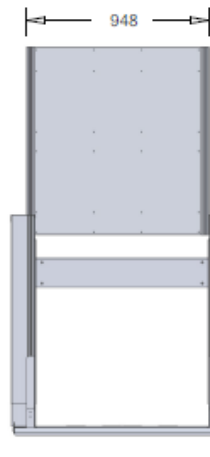
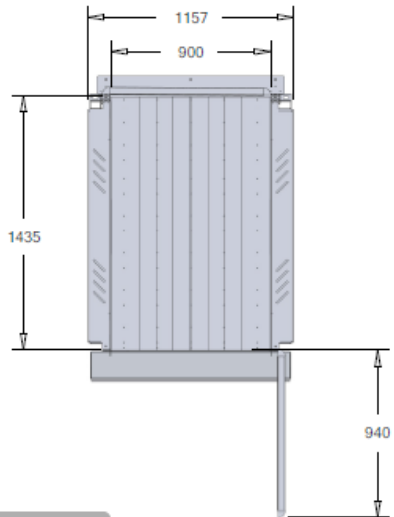

Minimum height from floor to platform 37 mm

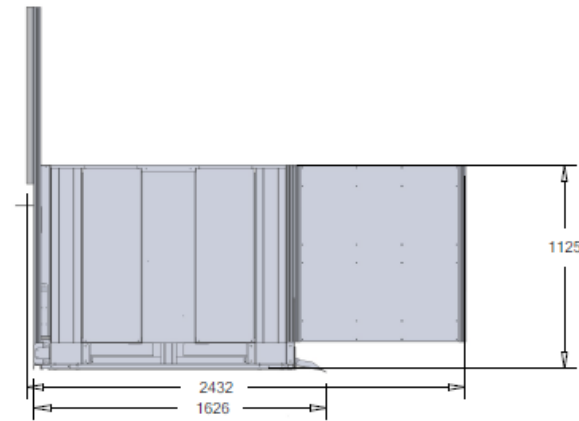

1.00 x 8.50 in

LIFT ORDER

- Indoors
 - Outdoors
 - Manual gates
 - Automatic gates
 - Car gate hinged left hand side
 - Car gate hinged right hand side
 - Landing gate hinged left hand side
 - Landing gate hinged right hand side
- Lift travel _____ mm

APPROVAL

Name

Company

Signature

Date